















	X 4		X 8
	X 4		X 4
	X 4		X 4
	X 1		X 8
	X 1		X 4
	X 4		

	X 4		X 4
	X 4		X 4
			X 2

			
FIAT	Multipla I	5	98>03
FIAT	Multipla II	5	04>10
INFINITI	Q30	5	16>
MERCEDES	A (W176)	5	13>15
MERCEDES	B (W246)	5	12>14
MERCEDES	B (W246)	5	15>
MERCEDES	CLA (C117)	4	13>15
MERCEDES	CLA (C117)	4	15>
MERCEDES	CLA Shooting Brake (X117)	5	15>
MERCEDES	GLE Coupé (C292)	5	15>



M1	M2
7,4	4,9
7,4	4,9
11,1	7,7
11,4	7,6
12,9	10,4
12,9	10,4
10,4	9,1
10,9	9,6
10,9	7,4
6,9	9,9

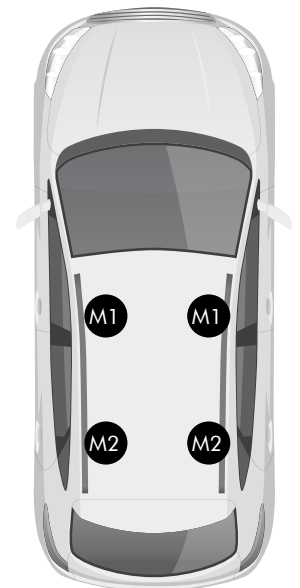

Le tabelle di applicabilità sono soggette ad invecchiamento e/o modifiche, in caso di dubbio si consiglia di consultare il sito www.k39.it costantemente aggiornato.

The applicability tables are subject to aging and/or changes, in case of doubt it is advisable to consult the constantly updated website www.k39.it.

1a

4 x

Clik!

K1 MEDIUM
K1 PRO
K1 PRO ALU

1b

4 x

K1
K1 MEDIUM
K1 PRO
K1 PRO ALU

2

4 x

B

3

4 x

4

2 x M1

M1 M1b

→ M1

2 x M2

M2 M2b

← M2

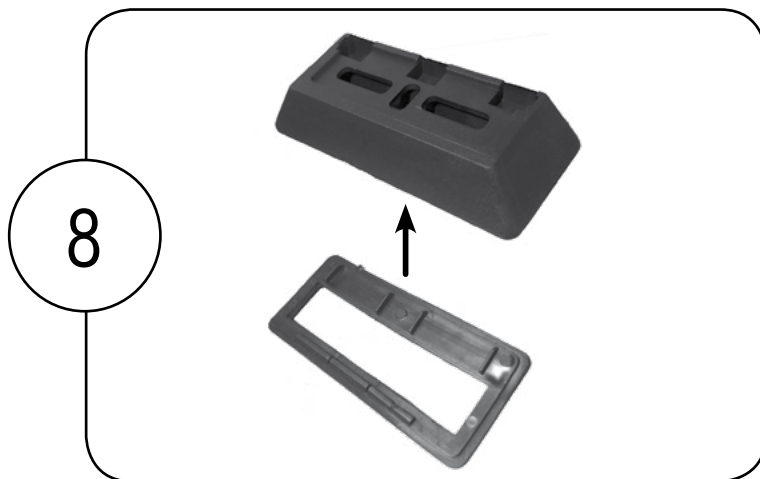
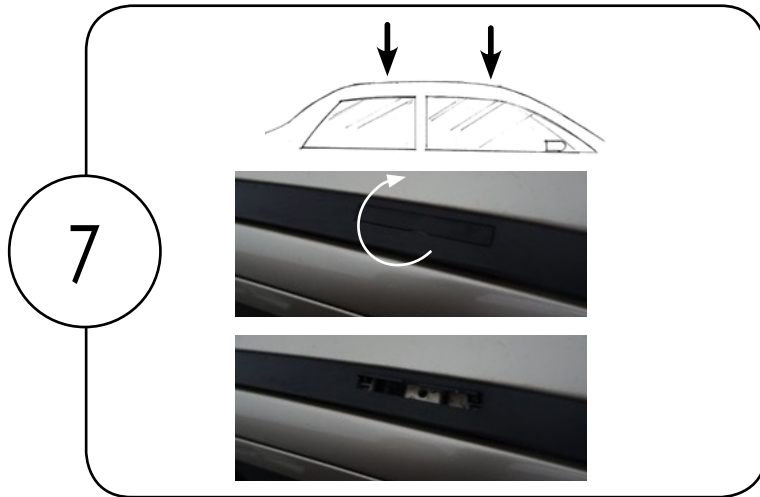
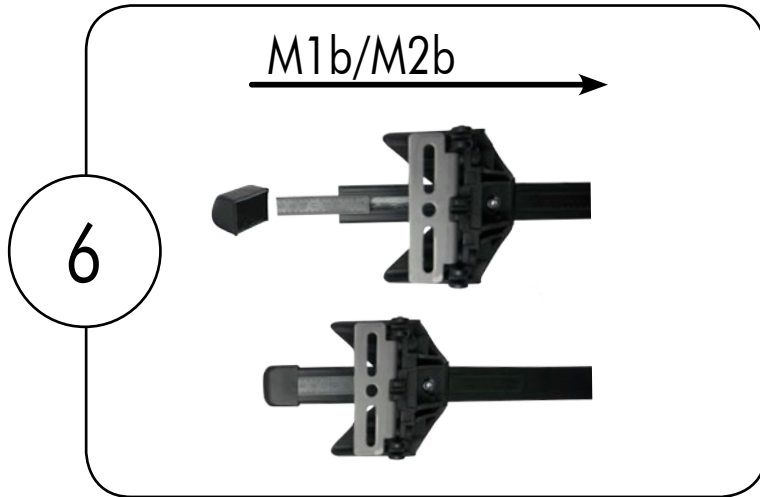
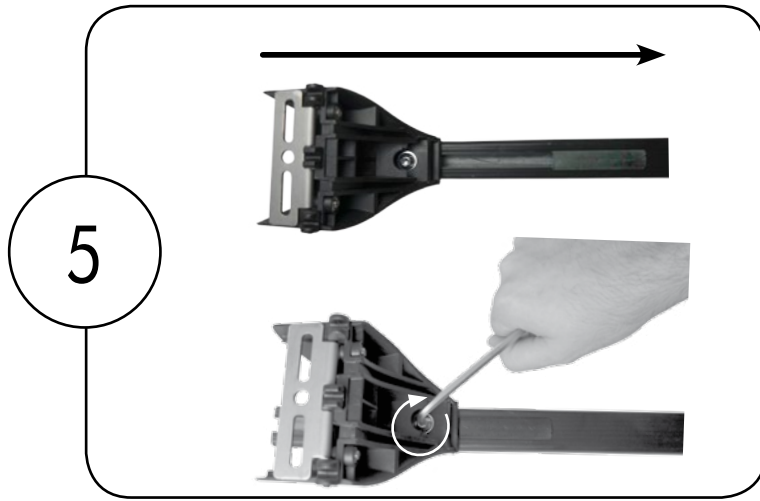

9

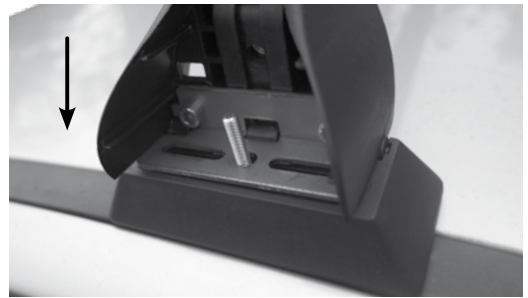
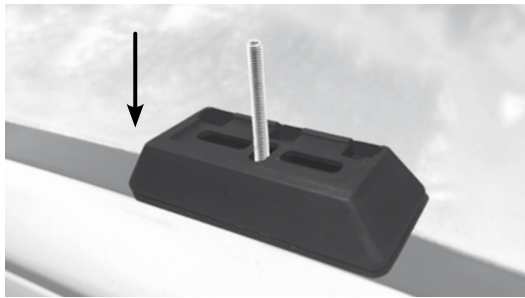
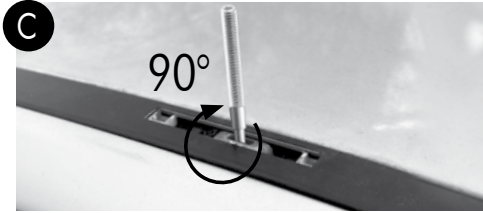
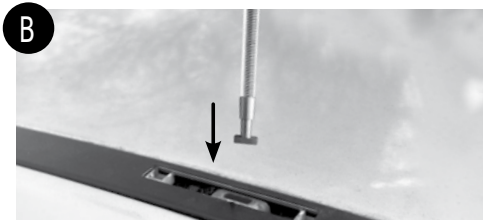
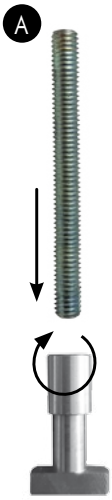

10

X 4

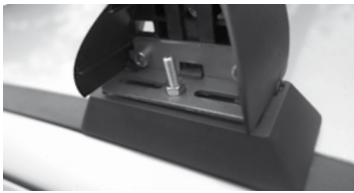

11



K1



K1 MEDIUM
K1 PRO
K1 PRO ALU

MAX
75 kg



NO

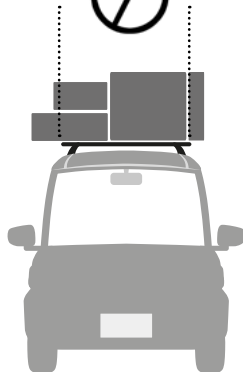

OK

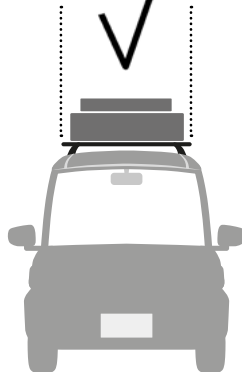

NO

