



| CASA AUTO       | MODELLO  | PORTE | ANNO  | M1   | M2   | G1 | F1 | G2 | F2 | T1 | T2 |
|-----------------|--|-------|-------|------|------|----|----|----|----|----|----|
| AUDI            | A3 (8V) e-tron   | 5     | 12>19 | 13,6 | 12,3 | 06 | A  | 06 | A  | 25 | 41 |
| AUDI            | A3 (8VA) Sportback                                       | 5     | 13>19 | 13,6 | 12,3 | 06 | A  | 06 | A  | 25 | 41 |
| AUDI            | S3 Sportback   | 5     | 13>19 | 13,6 | 12,3 | 06 | A  | 06 | A  | 25 | 41 |
| BMW             | X1 (E84)   | 5     | 09>15 | 8,3  | 8,3  | 06 | A  | 06 | A  | 25 | 47 |
| BMW             | X3 (E83)   | 5     | 04>10 | 7,7  | 6,5  | 06 | A  | 06 | A  | 20 | 40 |
| CHEVROLET       | Volt   | 4     | 12>   | 5,6  | 4,6  | 06 | A  | 06 | A  | 43 | 26 |
| CITROEN         | C5 (Mk1)   | 4     | 01>08 | 4,1  | 2,0  | 06 | A  | 06 | A  | 22 | 45 |
| CITROEN         | C-Zero   | 5     | 10>19 | 13,6 | 14,0 | 06 | A  | 06 | A  | 26 | 40 |
| FIAT            | Bravo  | 5     | 07>14 | 6,7  | 5,6  | 06 | A  | 06 | A  | 31 | 47 |
| FORD            | Ecosport   | 5     | 12>   | 5,3  | 5,3  | 06 | B  | 06 | B  | 20 | 46 |
| FORD            | Focus III Station Wagon                                  | 5     | 11>14 | 7,5  | 6,2  | 06 | A  | 06 | A  | 16 | 47 |
| FORD            | Focus III Station Wagon                                  | 5     | 14>   | 7,4  | 6,3  | 06 | A  | 06 | A  | 23 | 48 |
| FORD            | Mondeo IV Station Wagon                                  | 5     | 14>   | 7,8  | 6,5  | 06 | B  | 06 | B  | 24 | 46 |
| HYUNDAI         | i30 (GD)   | 5     | 11>15 | 6,2  | 7,8  | 06 | B  | 06 | B  | 19 | 42 |
| HYUNDAI         | Santa Fe (DM)  | 5     | 12>18 | 11,0 | 9,9  | 06 | A  | 06 | A  | 26 | 37 |
| JEEP            | Cherokee (KL)  | 5     | 14>   | 10,0 | 10,3 | 06 | A  | 06 | A  | 17 | X  |
| KIA             | Carens (RP)  | 5     | 13>   | 10,1 | 9,1  | 06 | A  | 06 | A  | 27 | 47 |
| KIA             | Cee'D (EU)   | 5     | 12>   | 6,6  | 5,7  | 06 | B  | 06 | B  | 23 | 46 |
| KIA             | Sportage (SL)  | 5     | 10>13 | 9,7  | 8,7  | 06 | A  | 06 | A  | 10 | 60 |
| KIA             | Sportage (QL)  | 5     | 16>21 | 8,6  | 8,5  | 06 | B  | 06 | B  | 20 | 45 |
| LANCIA          | Ypsilon  | 5     | 11>15 | 13,7 | 13,4 | 06 | A  | 06 | A  | X  | X  |
| LEXUS           | CT Hybrid  | 5     | 11>   | 11,2 | 12,2 | 06 | B  | 06 | B  | 27 | 38 |
| MAZDA           | 2 (DJ)   | 5     | 14>   | 11,7 | 11,9 | 06 | B  | 06 | B  | 26 | 35 |
| MAZDA           | Cx-30  | 5     | 19>   | 9,1  | 5,5  | 06 | B  | 06 | A  | 20 | 40 |
| MAZDA           | Cx-5   | 5     | 12>15 | 10,2 | 8,2  | 06 | A  | 06 | A  | 24 | 44 |
| MINI            | Cooper   | 5     | 14>   | 13,7 | 12,9 | 06 | A  | 06 | A  | 30 | 25 |
| MINI            | Cooper S   | 5     | 14>   | 13,7 | 12,9 | 06 | A  | 06 | A  | 30 | 25 |
| MINI            | One  | 5     | 14>   | 13,7 | 12,9 | 06 | A  | 06 | A  | 30 | 25 |
| MINI            | Cooper   | 5     | 14>   | 13,7 | 12,9 | 06 | A  | 06 | A  | 30 | 25 |
| MITSUBISHI      | I-Miev   | 5     | 10>   | 14,3 | 14,3 | 06 | A  | 06 | A  | 27 | 35 |
| MITSUBISHI      | Spacestar  | 5     | 16>   | 4,6  | 2,2  | 06 | B  | 06 | B  | X  | X  |
| NISSAN          | Leaf   | 5     | 10>16 | 6,3  | 7,0  | 06 | A  | 06 | A  | 25 | 40 |
| NISSAN          | Leaf   | 5     | 16>18 | 8,6  | 8,3  | 06 | B  | 06 | B  | 27 | 48 |
| NISSAN          | Pulsar   | 5     | 14>   | 5,9  | 5,9  | 06 | A  | 06 | A  | 5  | 63 |
| OPEL / VAUXHALL | Ampera   | 4     | 12>   | 5,6  | 4,6  | 06 | A  | 06 | A  | 43 | 26 |
| PEUGEOT         | Ion  | 5     | 11>   | 14,3 | 14,3 | 06 | A  | 06 | A  | 27 | 35 |
| RENAULT         | Grand Scenic III (No per tetto vetro-Not for glass roof) | 5     | 09>13 | 9,2  | 8,8  | 06 | A  | 06 | A  | 23 | 41 |
| RENAULT         | Grand Scenic III (No per tetto vetro-Not for glass roof) | 5     | 13>16 | 13,1 | 12,9 | 06 | A  | 06 | A  | 29 | 35 |
| RENAULT         | Megane III Coupé   | 3     | 09>   | 5,0  | 6,4  | 06 | A  | 06 | A  | 41 | 12 |
| RENAULT         | Scenic III (No per tetto vetro-Not for glass roof)       | 5     | 09>13 | 9,2  | 8,8  | 06 | A  | 06 | A  | 23 | 41 |
| RENAULT         | Scenic III (No per tetto vetro-Not for glass roof)       | 5     | 13>16 | 13,1 | 12,9 | 06 | A  | 06 | A  | 29 | 35 |
| RENAULT         | Scenic X Mod   | 5     | 09>13 | 9,2  | 8,4  | 06 | A  | 06 | A  | 23 | 41 |
| SEAT            | Altea  | 5     | 04>09 | 4,9  | 4,0  | 06 | A  | 06 | A  | 29 | 45 |
| SEAT            | Leon II (1P)   | 4     | 05>13 | 5,5  | 4,0  | 06 | A  | 06 | A  | 21 | 45 |
| SEAT            | Mii  | 3     | 12>   | 5,7  | 5,4  | 06 | A  | 06 | A  | 43 | 25 |
| SKODA           | Citigo   | 3     | 12>   | 5,7  | 5,4  | 06 | A  | 06 | A  | 43 | 25 |
| SKODA           | Citigo   | 5     | 12>   | 5,7  | 5,3  | 06 | A  | 06 | A  | 30 | 40 |
| TATA            | Aria   | 5     | 12>   | 13,6 | 12,5 | 06 | A  | 06 | A  | 29 | 60 |
| TATA            | Vista  | 5     | 10>   | 6,0  | 7,0  | 06 | B  | 06 | B  | 22 | 38 |
| VOLKSWAGEN      | E Up!  | 5     | 14>   | 5,7  | 5,3  | 06 | A  | 06 | A  | 30 | 40 |
| VOLKSWAGEN      | Golf Sport Van   | 5     | 14>   | 6,6  | 5,2  | 06 | A  | 06 | A  | 32 | 45 |
| VOLKSWAGEN      | Up!  | 3     | 12>16 | 5,7  | 5,3  | 06 | A  | 06 | A  | 30 | 40 |
| VOLKSWAGEN      | Up!  | 5     | 11>16 | 5,7  | 5,4  | 06 | A  | 06 | A  | 43 | 25 |
| VOLKSWAGEN      | Up!  | 3     | 16>   | 5,7  | 5,3  | 06 | A  | 06 | A  | 30 | 40 |
| VOLKSWAGEN      | Up!  | 5     | 16>   | 5,7  | 5,4  | 06 | A  | 06 | A  | 43 | 25 |

X = predisposizione originale



X =

1

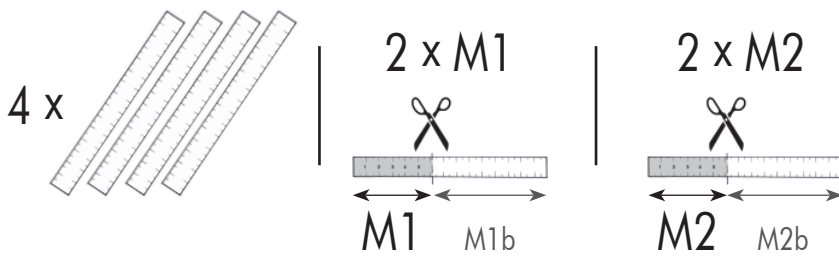
 Tab. 1:  
M1  
M2

Tagliare i 4 metri in dotazione alla misura M1 ed M2 riportate in tabella

2

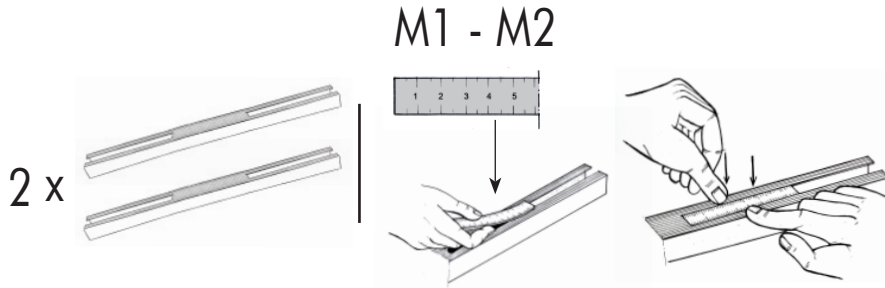

Inserire il metro tagliato in misura M1 nelle 2 cave della barra anteriore, portandolo fine a fine corsa.  
Ripetere l'operazione per la barra posteriore con i metri tagliati in misura M2.

3

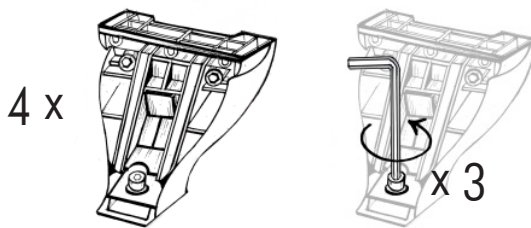

Prendere i 4 piedi dalla scatola, allentare la vite affinché i piedi possano entrare nella cava.  
Prendere il primo piede ed inserirlo in cava facendo **ATTENZIONE** a non sormontare il metro precedentemente inserito, stringere con forza la vite del piede.  
Ripetere l'operazione per tutti i 4 piedi ciascuno in una cava.

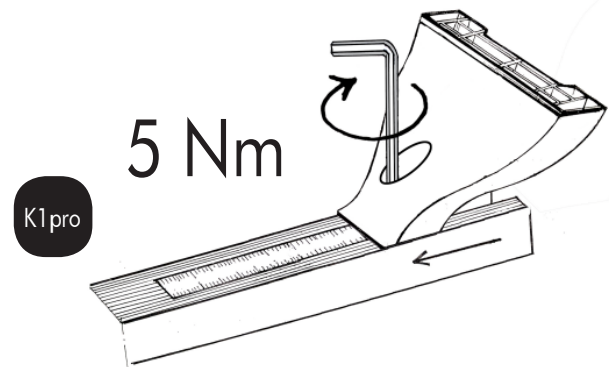
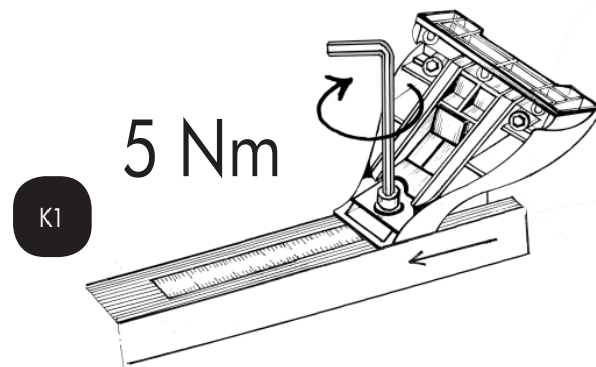

4



Inserire l'avanzo del metro tagliato (M1b per la barra anteriore ed M2b per la barra posteriore) per coprire la cava scoperta.

Ripetere l'operazione per tutte e 2 le barre.  
Inserire, infine, i 4 tappi come indicato in figura.

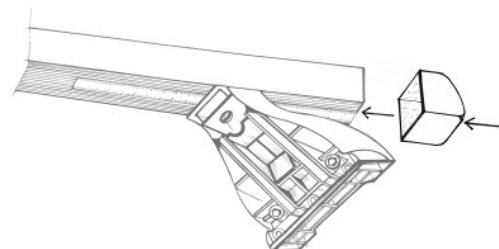
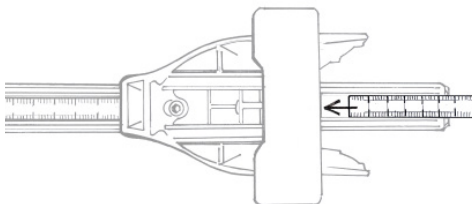

5

 Tab. 1:  
G1-F1  
G2-F2

4 x

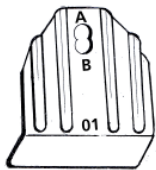
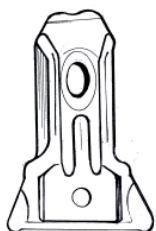

8x14

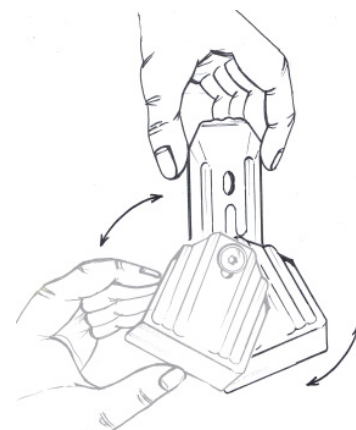
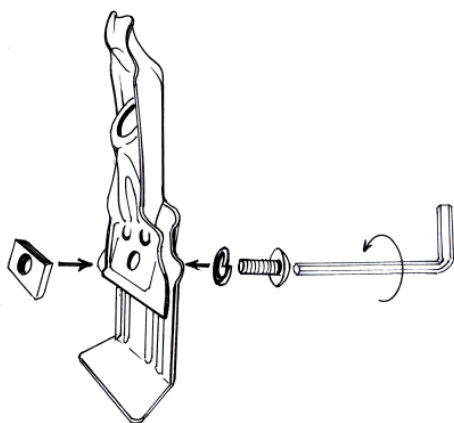

Assemblare le 4 GANASCINE come mostrato in figura, facendo **ATTENZIONE** a rispettare le misure riportate in tabella. Lasciare la parte inferiore della ganascina lasca.

6

8x50

4 x

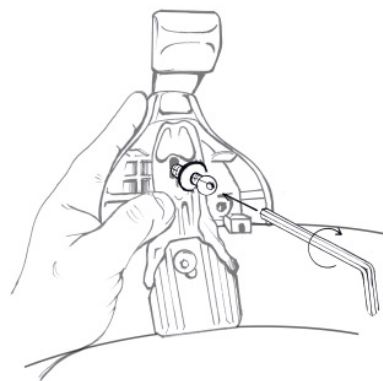
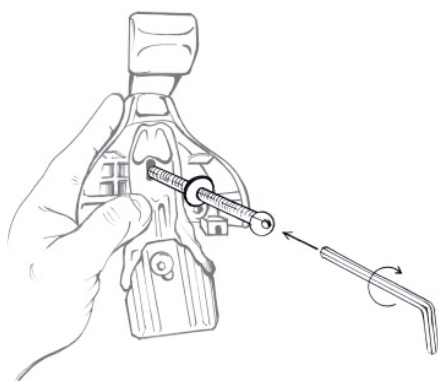

Posizionare la barra anteriore e la barra posteriore sul tetto dell'autovettura. Fissare le ganascine ai 4 piedi facendo **ATTENZIONE** a non stringere completamente la vite.

7

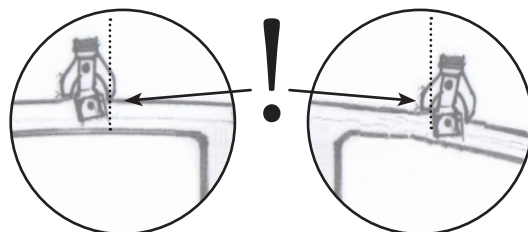
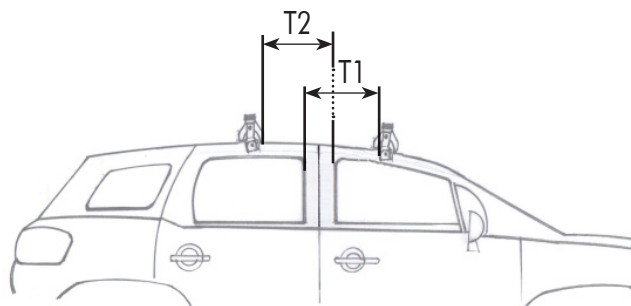
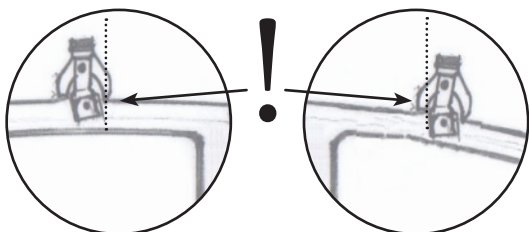
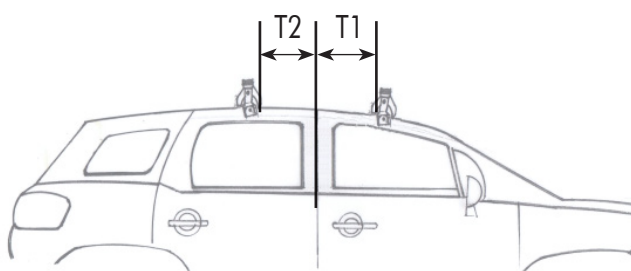
 Tab. 1:  
T1  
T2

8

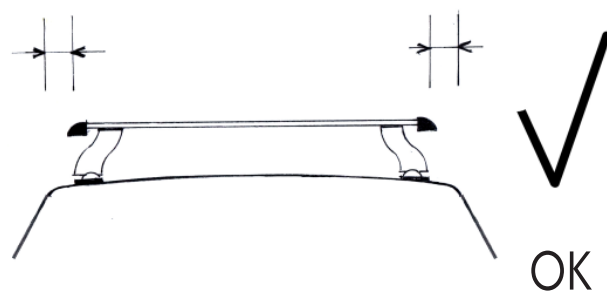
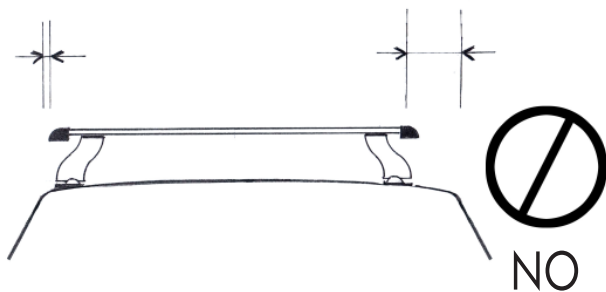

9

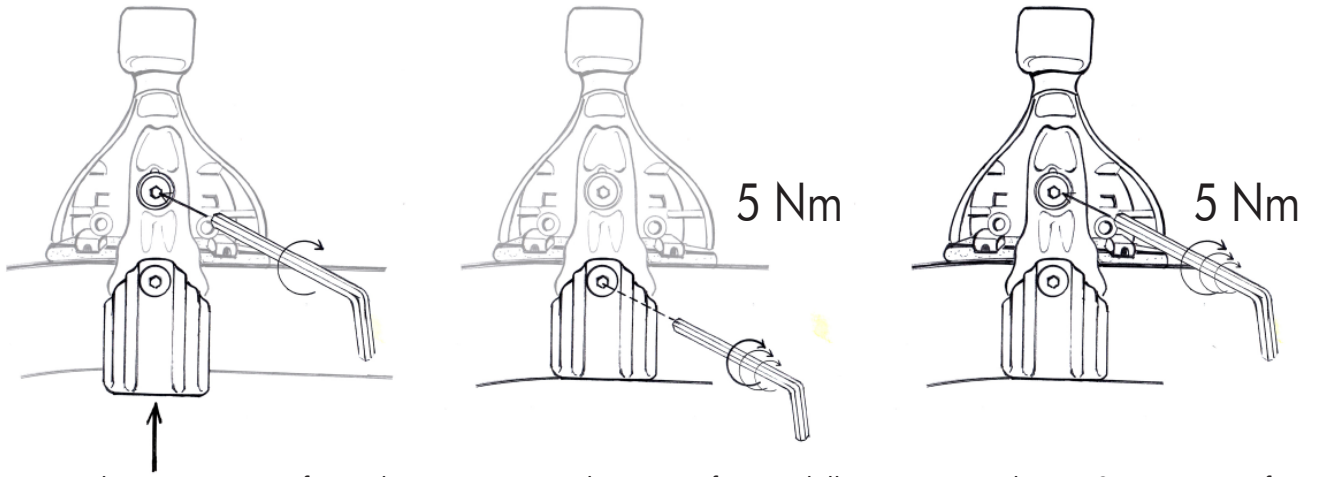

Stringere la vite superiore fino ad accompagnare la parte inferiore della ganascina al tetto. Stringere con forza la vite inferiore. Stringere con forza la vite superiore facendo **ATTENZIONE** a non spostare la centratura delle barre. Per ottenere il risultato corretto stringere le viti alternando il lato destro al lato sinistro in maniera uniforme.

10a



K1



  
x 4

10b



K1pro



  
x 4

MAX  
55 kg



 NO

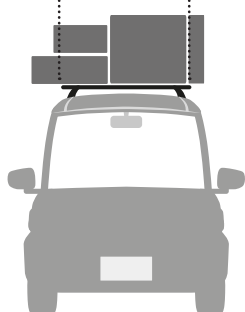

 OK



 NO

