

CASA AUTO	MODELLO	PORTE	ANNO
AUDI	A4 (B5/8D)	4	94>00
CITROEN	Ax	5	81>98
CITROEN	Saxo	5	96>04
FORD	Fiesta IV	5	95>02
FORD	Ka +	5	16>
HONDA	Jazz III restyling	5	15>19
MAZDA	121	4	91>02
MERCEDES	A (W168)	5	97>04
NISSAN	Micra (K11)	5	92>03
PEUGEOT	106	5	92>04
TOYOTA	Hilux (AN130)	5	15>

M1	M2
10,8	11,1
7,8	7,8
6,3	5,0
7,8	7,8
13,7	12,0
14,7	11,7
7,8	7,8
12,6	10,6
6,8	6,0
6,3	5,9
8,7	8,2

G1	F1	G2	F2
14	1 foro A	14	1 foro A
14	1 foro A	14	1 foro A
14	1 foro A	14	1 foro A
14	1 foro A	14	1 foro A
14	1 foro A	14	1 foro A
14	1 foro A	14	1 foro A
14	1 foro A	14	1 foro A
14	1 foro A	14	1 foro A
14	1 foro A	14	1 foro A
14	1 foro A	14	1 foro A
14	1 foro A	14	1 foro A

T1	T2
X	X
35	35
35	35
35	35
26	40
27	38
35	35
X	X
35	35
24	33
22	45

Le tabelle di applicabilità sono soggette ad invecchiamento e/o modifiche, in caso di dubbio si consiglia di consultare il sito www.k39.it costantemente aggiornato.
The applicability tables are subject to aging and/or changes, in case of doubt it is advisable to consult the constantly updated website www.k39.it.



1

 Tab. 1:
M1
M2

4 x

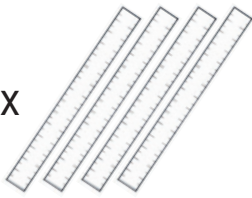

2 x M1

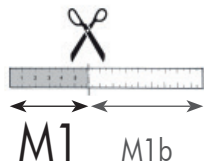

2 x M2

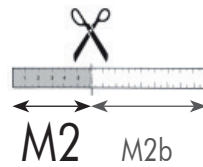

Tagliare i 4 metri in dotazione alla misura M1 ed M2 riportate in tabella

2

2 x



M1 - M2

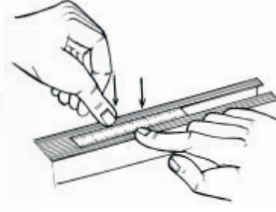
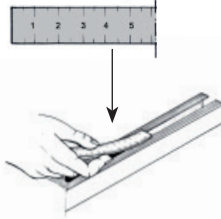

Inserire il metro tagliato in misura M1 nelle 2 cave della barra anteriore, portandolo fine a fine corsa.
Ripetere l'operazione per la barra posteriore con i metri tagliati in misura M2.

3

4 x

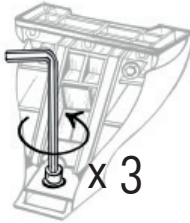

x 3

Prendere i 4 piedi dalla scatola, allentare la vite affinché i piedi possano entrare nella cava.
Prendere il primo piede ed inserirlo in cava facendo **ATTENZIONE** a non sormontare il metro precedentemente inserito, stringere con forza la vite del piede.
Ripetere l'operazione per tutti i 4 piedi ciascuno in una cava.

5 Nm

K1

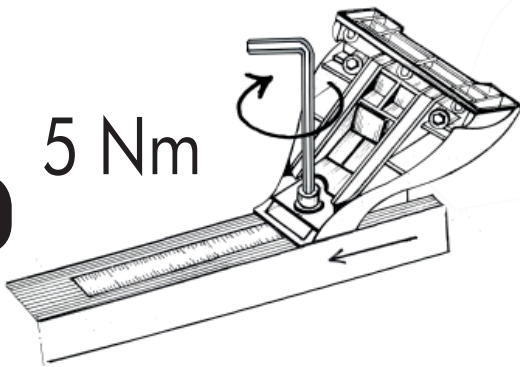

5 Nm

K1pro

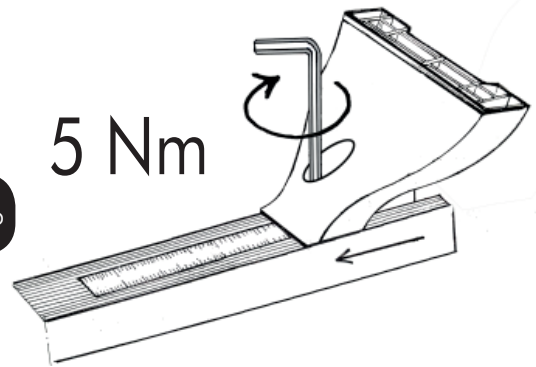

4

M1b - M2b



Inserire l'avanzo del metro tagliato (M1b per la barra anteriore ed M2b per la barra posteriore) per coprire la cava scoperta.

Ripetere l'operazione per tutte e 2 le barre.
Inserire, infine, i 4 tappi come indicato in figura.

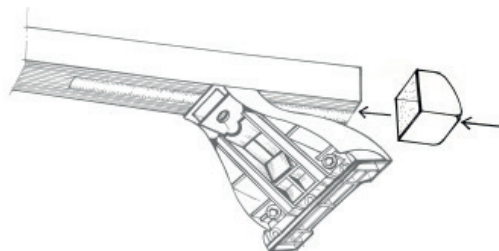
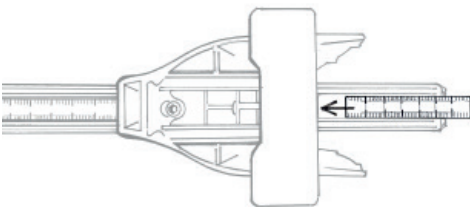

5

 Tab. 1:
G1-F1
G2-F2

4 x

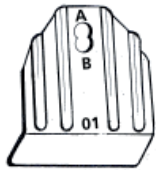

8x14

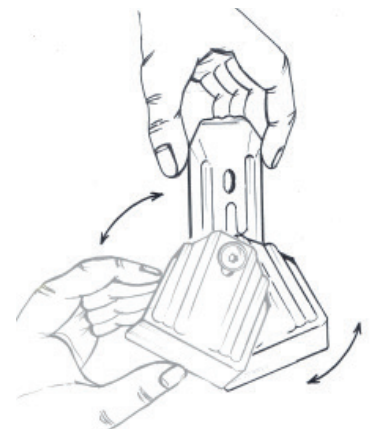
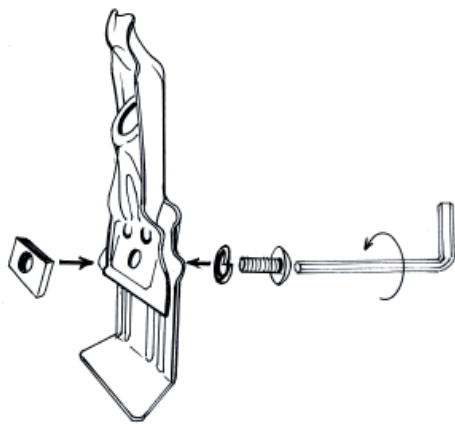

Assemblare le 4 GANASCINE come mostrato in figura, facendo **ATTENZIONE** a rispettare le misure riportate in tabella. Lasciare la parte inferiore della ganascina lasca.

6

8x50

4 x

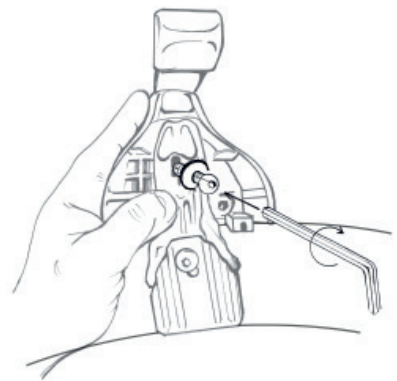
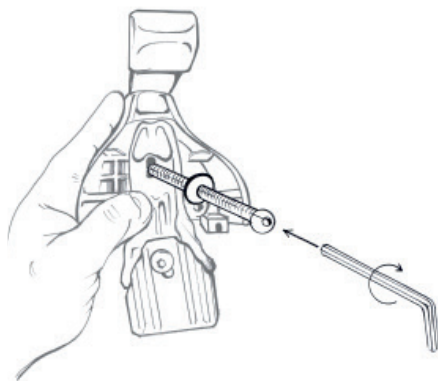

Posizionare la barra anteriore e la barra posteriore sul tetto dell'autovettura. Fissare le ganascine ai 4 piedi facendo **ATTENZIONE** a non stringere completamente la vite.

7

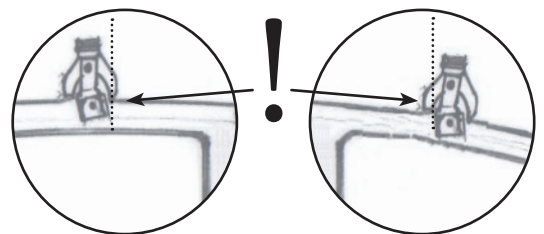
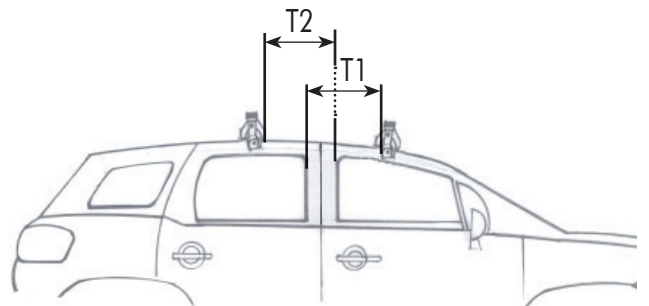
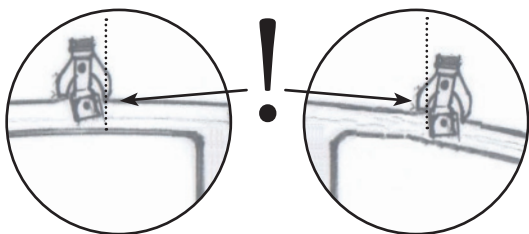
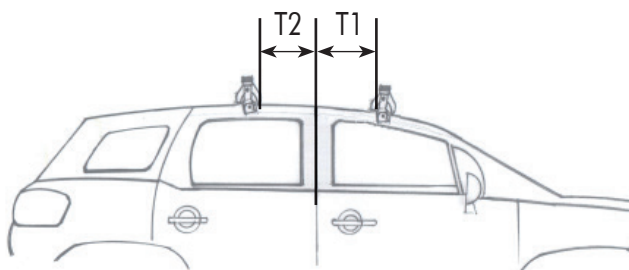
 Tab. 1:
T1
T2

8

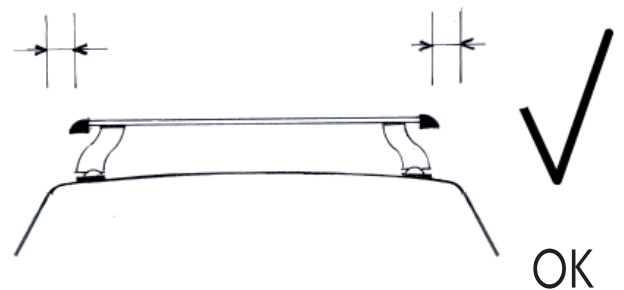
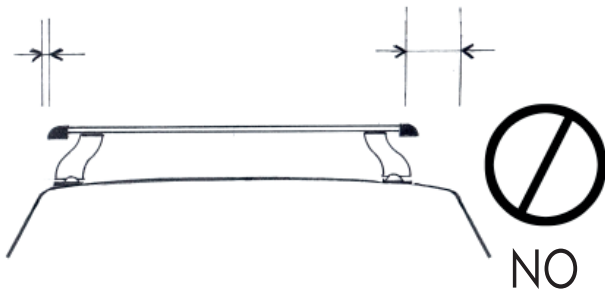

9

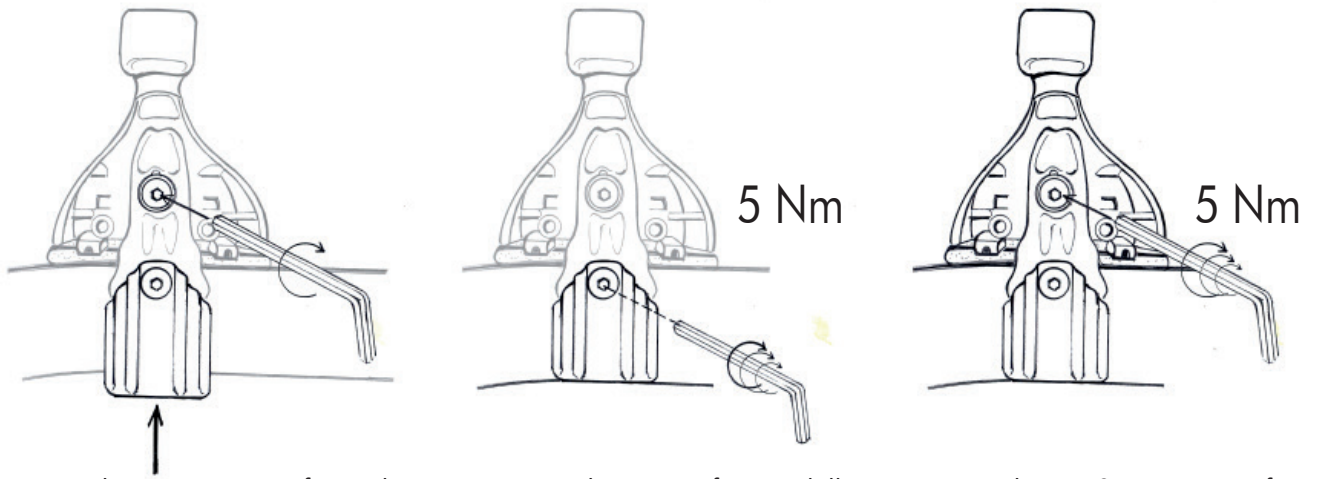

Stringere la vite superiore fino ad accompagnare la parte inferiore della ganascina al tetto. Stringere con forza la vite inferiore. Stringere con forza la vite superiore facendo **ATTENZIONE** a non spostare la centratura delle barre. Per ottenere il risultato corretto stringere le viti alternando il lato destro al lato sinistro in maniera uniforme.

10a



K1



x 4

10b



K1pro





x 4

MAX
55 kg

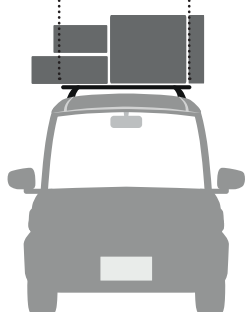

 NO



 OK



 NO

