

TAB. 1



CASA AUTO	MODELLO	PORTE	ANNO
CITROEN	C4 Picasso (Mk2)	5	13>18
CITROEN	C4 Spacetourer (Mk2)	5	18>

M1	M2
11,4	9,7
11,8	10,3

G1	F1	G2	F2
22	1 foro A	22	1 foro A
22	1 foro A	22	1 foro A

T1	T2
X	X
X	X

Le tabelle di applicabilità sono soggette ad invecchiamento e/o modifiche, in caso di dubbio si consiglia di consultare il sito www.k39.it costantemente aggiornato.
The applicability tables are subject to aging and/or changes, in case of doubt it is advisable to consult the constantly updated website www.k39.it.

X = predisposizione originale



1
Tab. 1:
M1
M2

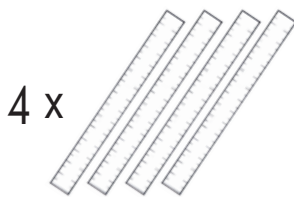

4 x

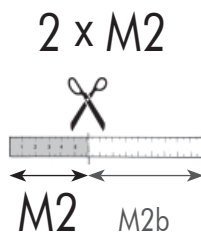
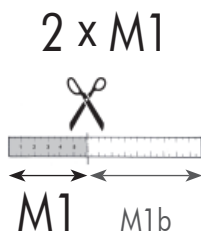

Tagliare i 4 metri in dotazione alla misura M1 ed M2 riportate in tabella

2

2 x



M1 - M2

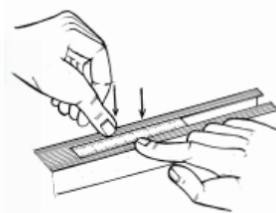
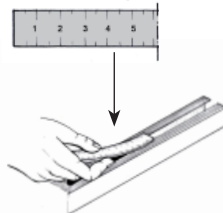

Inserire il metro tagliato in misura M1 nelle 2 cave della barra anteriore, portandolo fine a fine corsa.
Ripetere l'operazione per la barra posteriore con i metri tagliati in misura M2.

3

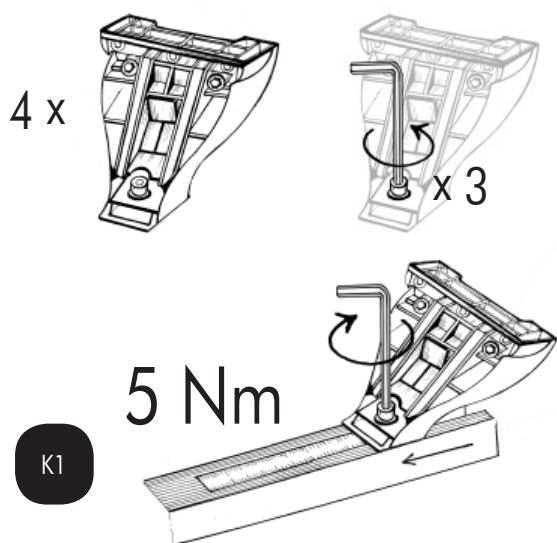

Prendere i 4 piedi dalla scatola, allentare la vite affinché i piedi possano entrare nella cava.
Prendere il primo piede ed inserirlo in cava facendo **ATTENZIONE** a non sormontare il metro precedentemente inserito, stringere con forza la vite del piede.
Ripetere l'operazione per tutti i 4 piedi ciascuno in una cava.

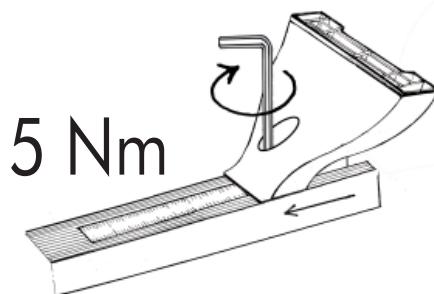

4



Inserire l'avanzo del metro tagliato (M1b per la barra anteriore ed M2b per la barra posteriore) per coprire la cava scoperta.
Ripetere l'operazione per tutte e 2 le barre.
Inserire, infine, i 4 tappi come indicato in figura.

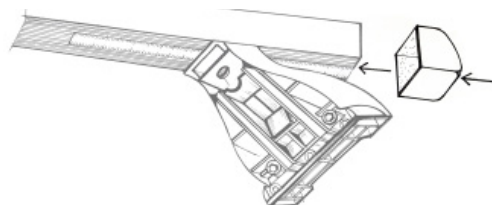
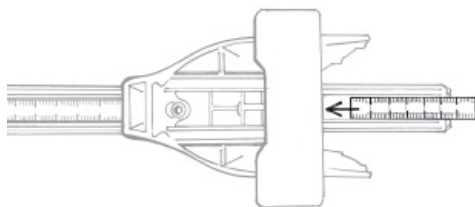

5



Tab. 1:
G1-F1
G2-F2

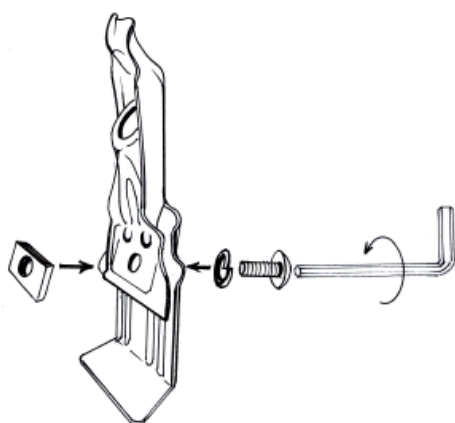
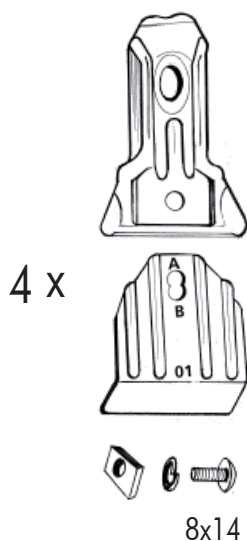

Assemblare le 4 GANASCINE come mostrato in figura, facendo **ATTENZIONE** a rispettare le misure riportate in tabella.
Lasciare la parte inferiore della ganascina lasca.

6

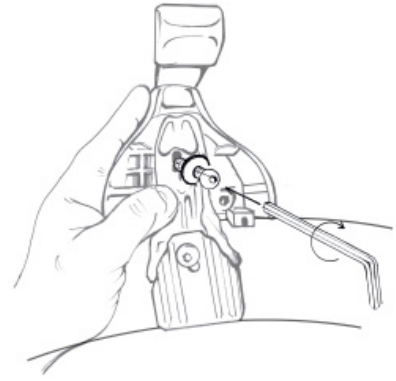
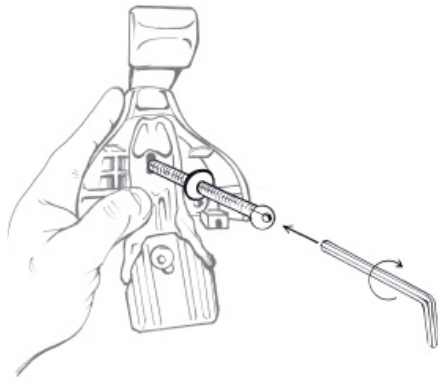

Posizionare la barra anteriore e la barra posteriore sul tetto dell'autovettura. Fissare le ganascine ai 4 piedi facendo **ATTENZIONE** a non stringere completamente la vite.

7

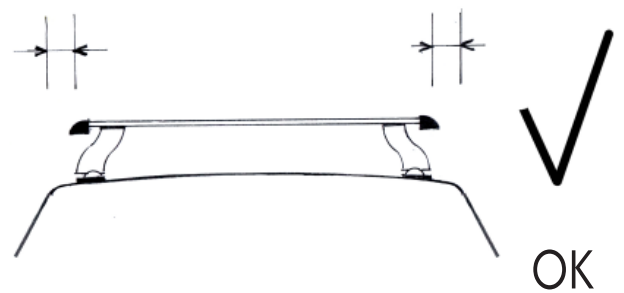
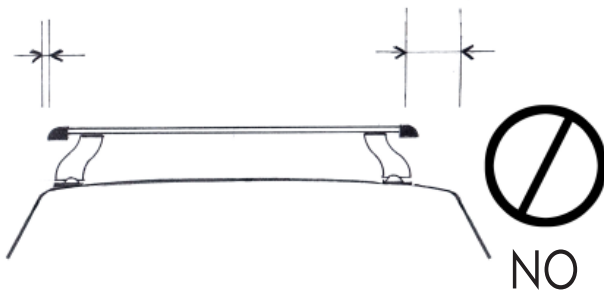

8

4 x
6x16

CASA AUTO	MODELLO	PORTE	ANNO
CITROEN	C4 Picasso (Mk2)	5	13>18
PEUGEOT	3008	5	16>
PEUGEOT	5008	5	17>

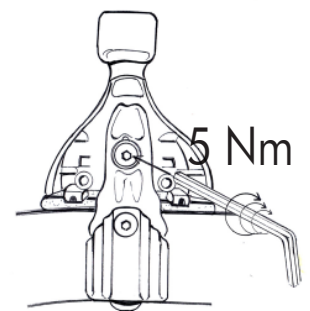
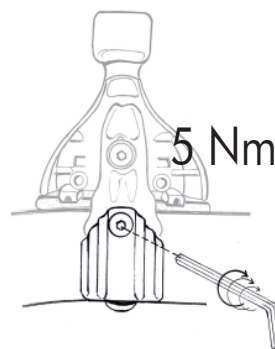
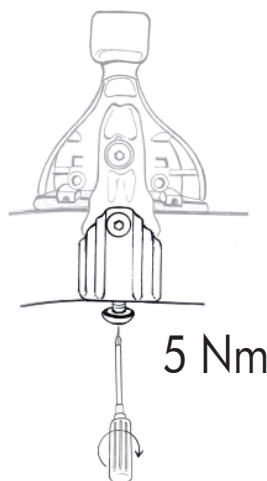
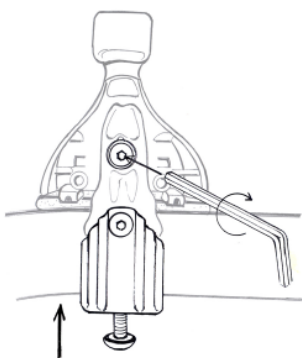

Stringere la vite superiore fino ad accompagnare la parte inferiore della ganascina al tetto. Stringere la vite inferiore arrivando a fine corsa. Stringere con forza la vite di congiunzione della ganascia. Stringere con forza la vite superiore facendo **ATTENZIONE** a non spostare la centratura delle barre. Per ottenere il risultato corretto stringere le viti alternando il lato destro al lato sinistro in maniera uniforme.

9a



K1



x 4

9b



K1pro



x 4

MAX
55 kg



NO

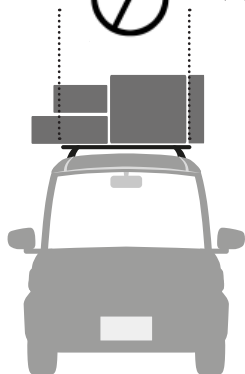

OK

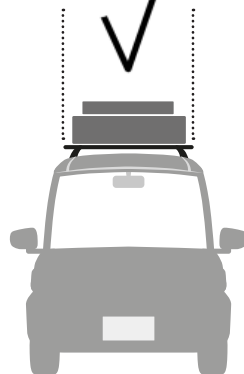

NO

