



CASA AUTO	MODELLO	PORTE	ANNO
RENAULT	Clio III	5	05 > 12
RENAULT	Clio Collection	5	12 > 16
RENAULT	Gran Modus	5	07 > 13
RENAULT	Modus	5	04 > 13

M1	M2
10,3	7,6
10,3	7,6
5,0	2,2
6,9	4,3

G1	F1	G2	F2
30	fissa	30	fissa
30	fissa	30	fissa
30	fissa	30	fissa
30	fissa	30	fissa

T1	T2
X	X
X	X
X	X
X	X

Le tabelle di applicabilità sono soggette ad invecchiamento e/o modifiche, in caso di dubbio si consiglia di consultare il sito www.k39.it costantemente aggiornato.
The applicability tables are subject to aging and/or changes, in case of doubt it is advisable to consult the constantly updated website www.k39.it.

1

 Tab. 1:
M1
M2

4 x

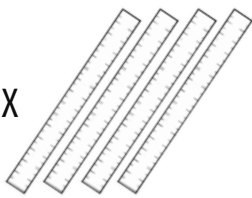

2 x M1



2 x M2

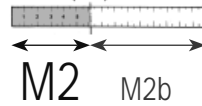

Tagliare i 4 metri in dotazione alla misura M1 ed M2 riportate in tabella

2

2 x



M1 - M2

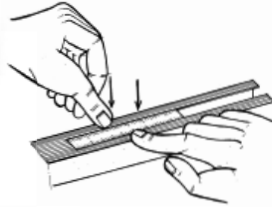
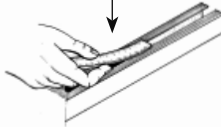
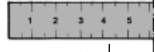

Inserire il metro tagliato in misura M1 nelle 2 cave della barra anteriore, portandolo fine a fine corsa.
Ripetere l'operazione per la barra posteriore con i metri tagliati in misura M2.

3

4 x

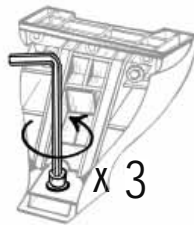

x 3

Prendere i 4 piedi dalla scatola, allentare la vite affinché i piedi possano entrare nella cava.
Prendere il primo piede ed inserirlo in cava facendo **ATTENZIONE** a non sormontare il metro precedentemente inserito, stringere con forza la vite del piede.
Ripetere l'operazione per tutti i 4 piedi ciascuno in una cava.

5 Nm

K1

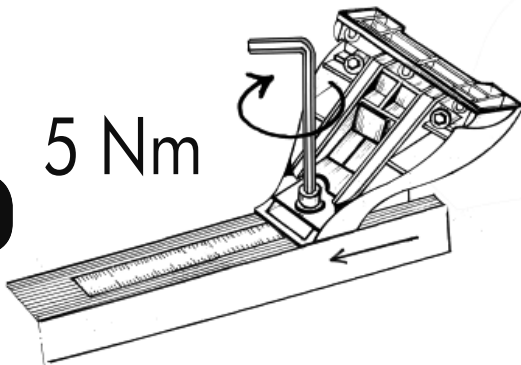

5 Nm

K1pro

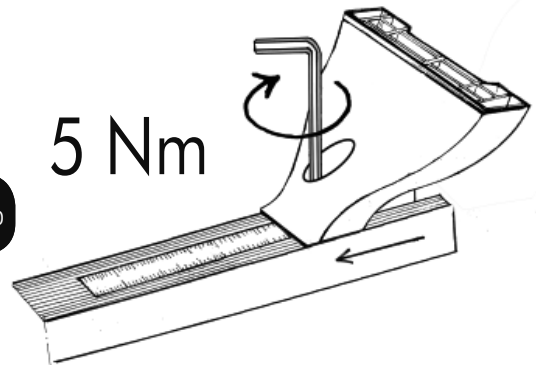

4

M1b - M2b

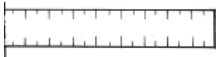

Inserire l'avanzo del metro tagliato (M1b per la barra anteriore ed M2b per la barra posteriore) per coprire la cava scoperta.

Ripetere l'operazione per tutte e 2 le barre.
Inserire, infine, i 4 tappi come indicato in figura.

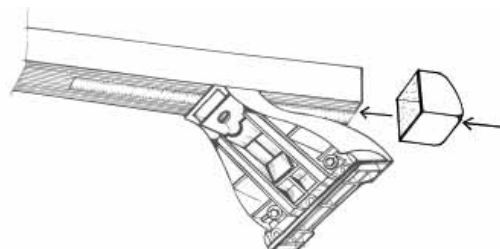
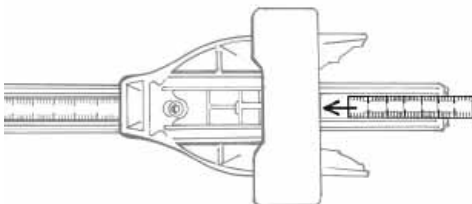

5

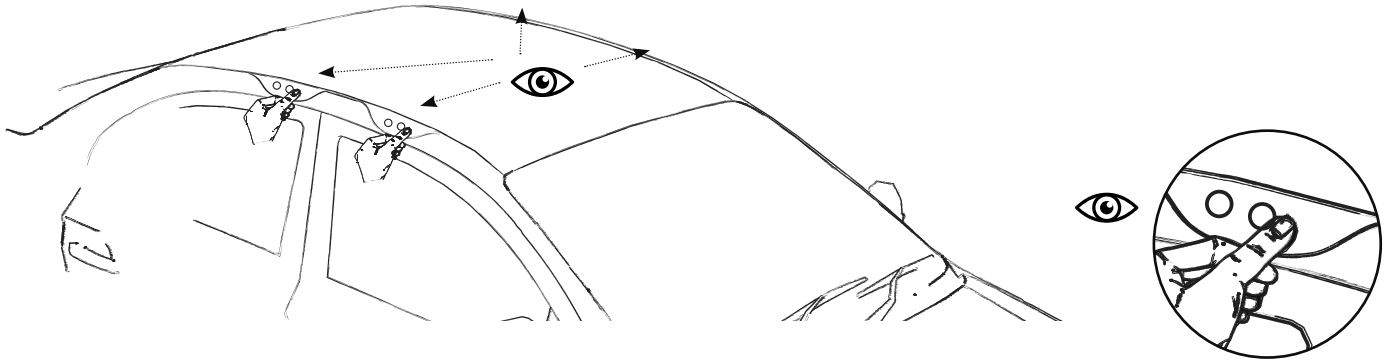

6

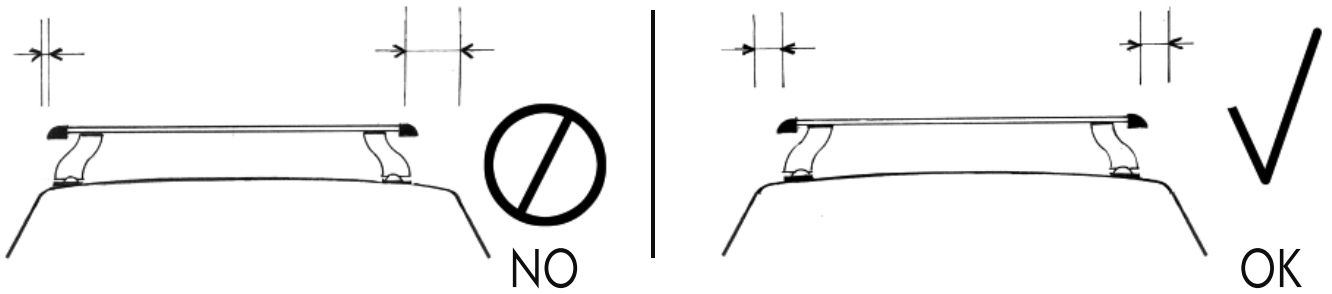

7

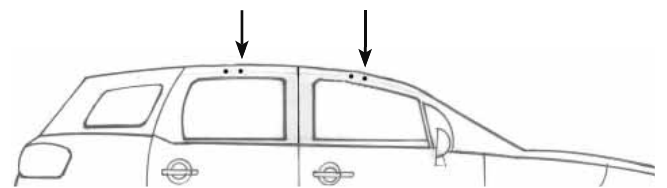
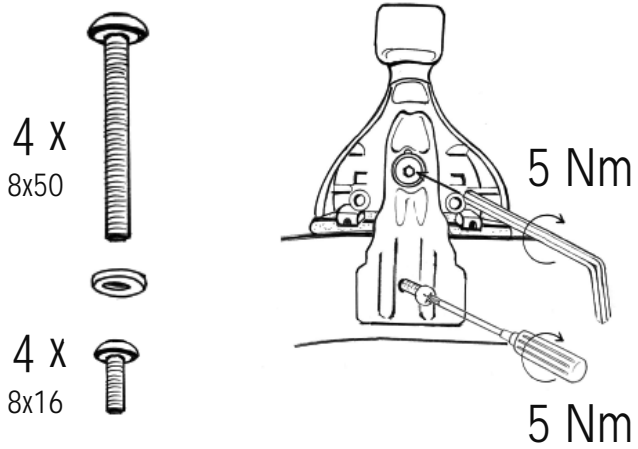

ATTENZIONE: utilizzare i fori indicati in figura della predisposizione originale.

Stringere con forza la vite facendo ATTENZIONE a non spostare la centratura delle barre. Per ottenere il risultato corretto stringere le viti alternando il lato destro al lato sinistro in maniera uniforme.

8a



K1



x 4

8b



K1pro





x 4

MAX
55 kg

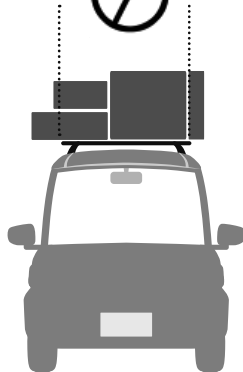

 NO



 OK

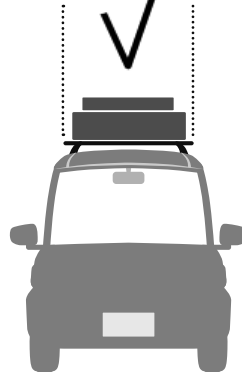

 NO

